

Assembly Instructions For

OLPL7307 (E) 5/09

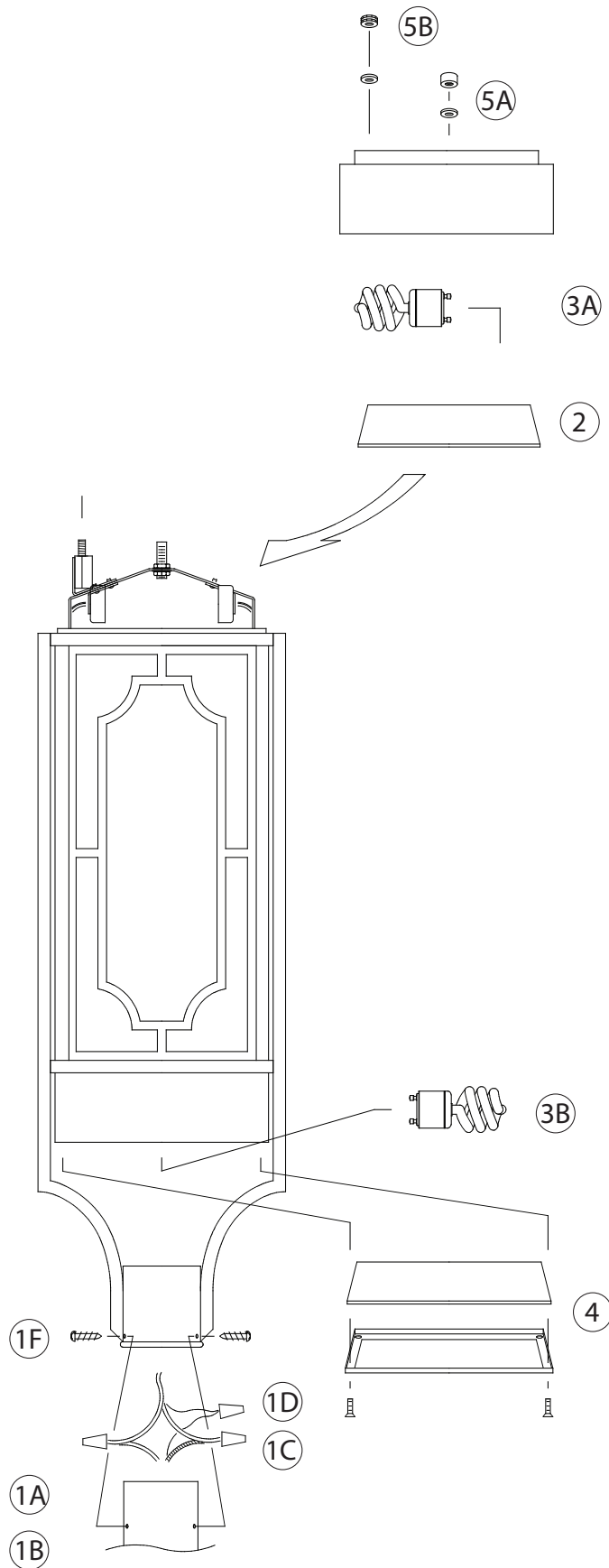

IMPORTANT TURN OFF THE POWER AT THE MAIN FUSE OR CIRCUIT BREAKER BOX BEFORE STARTING INSTALLATION

Carefully unpack and identify all parts before assembly.

1. Electrical installation onto post: If you are replacing an existing fixture, disconnect and remove the old fixture.
 - A) Slip post cup over post. Mark position of holes in post cup on post.
 - B) Remove post cup and expose the supply wiring from above post. Drill 1/8" (3mm) diameter pilot holes in post at places where marked.
 - C) Connect white fixture wire to white supply wire from post with wire connector. Connect black fixture wire to black supply wire from post with wire connector.

NOTE: Black wire from post may be red, round and smooth and/or have copper conductor. White wire from post may be square and ridged and/or have a silver conductor.
 - D) Connect fixture ground wire (without plastic insulation) to ground wire from post (usually with green insulation) with wire connector.

IMPORTANT: Never connect ground wire to black or white supply wires.
 - E) Tuck all wires inside of post.
 - F) Slip post cup onto post. Align holes in post cup with holes in post. Secure them together by fastening with sheet metal screws.
2. Install small glass plate by slipping below bridge, and then sitting inside center of fixture.
3. A. Install compact fluorescent lamps (GU-24 base, 13 Watt) (included) by inserting into slots in socket base, and then twist and lock.
B. Install another set of compact fluorescent lamps at bottom.
4. Lay large glass plate inside of square metal trim and then install onto bottom of fixture by fastening with four screws. **IMPORTANT: DO NOT OVER TIGHTEN.**
5. A. Install top cover by fastening with a rubber washer and cap nut onto center threaded pipe.
B. Fasten another rubber washer and a knurled nut onto rear photo sensor.

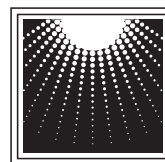

**MURRAY
FEISS**

Generation Brands™